

1 KNOWLEDGE ADVANCEMENTS

1. In the table below, list three different horse breeds and the following information about them.

Breed:			
Origin:			
Characteristics:			
Primary uses:			

2. What are the five basic coat colors? Name and briefly describe them.

- 1.
- 2.
- 3.
- 4.
- 5.

3. What are the five major variations to the basic coat colors? Name and briefly describe them.

- 1.
- 2.
- 3.
- 4.
- 5.

4. On the pictures below, draw the following face markings: star, stripe, blaze, snip, and bald face.

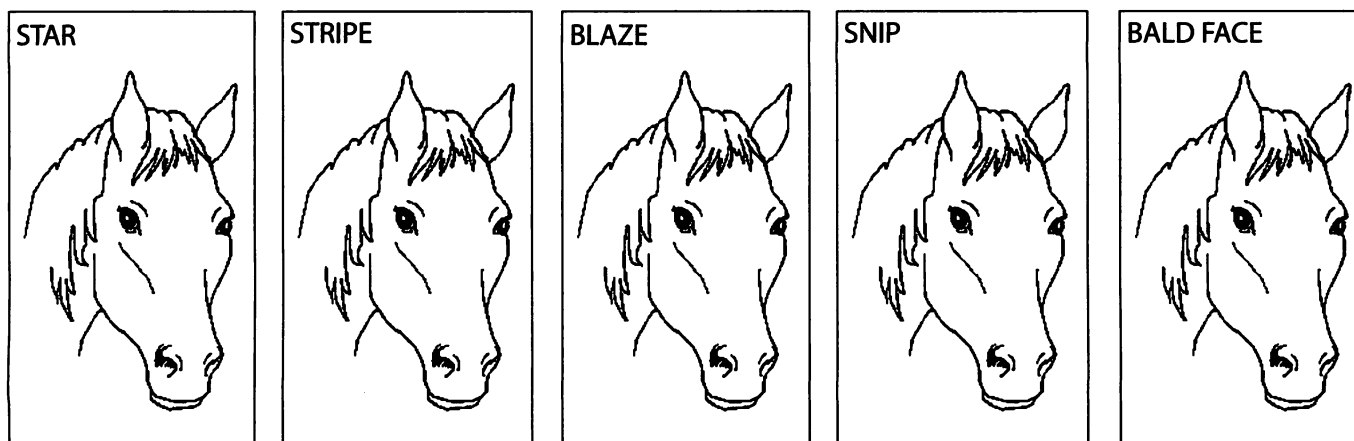

1 KNOWLEDGE ADVANCEMENTS (contd.)

5. Identify the following parts of the hunt seat saddle.
Write their names in the boxes.

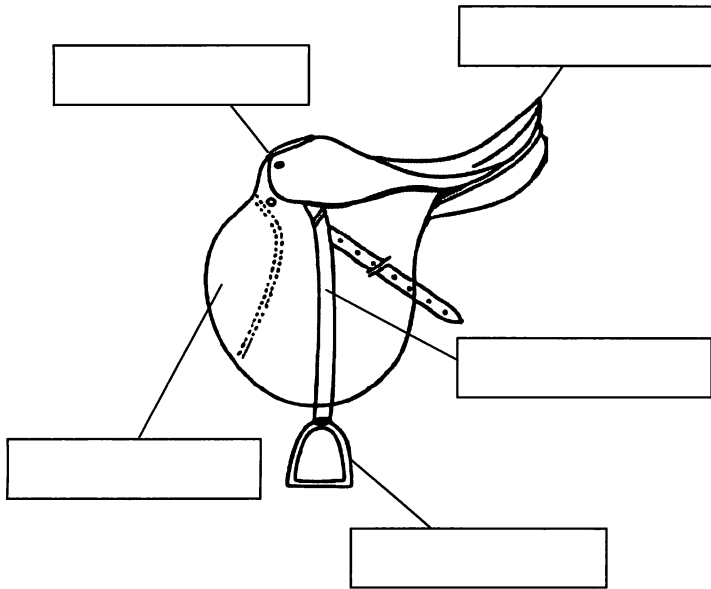

6. Identify the following parts of the English bridle.
Write their names in the boxes.

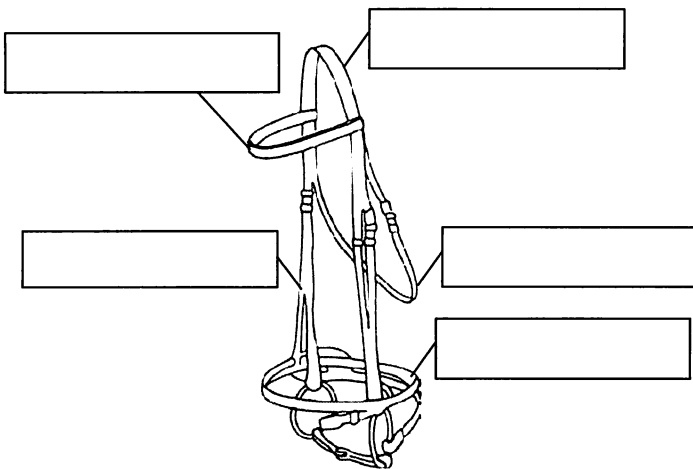

7. Number the order in which you would use the following grooming tools, with "1" as the first tool and "6" as the last.

- ___ Body brush
- ___ Mane and tail comb
- ___ Dandy brush
- ___ Cloth
- ___ Curry comb
- ___ Hoof pick

8. List three reasons why grooming is beneficial to your horse's health.

- 1.
- 2.
- 3.

9. Below are statements regarding catching and/or approaching a horse. Indicate whether the statements are true ("T") or false ("F").

- ___ When possible, approach the horse at an angle and come in near its shoulder.
- ___ Most horses are likely to jump and/or kick if they are startled.
- ___ If it is necessary to approach the horse from the rear, you should not speak to the horse to avoid startling it.
- ___ When behind the horse, you should stay close to its body.
- ___ You should use grain to catch a horse, even if other horses are present.

1 KNOWLEDGE ADVANCEMENTS (contd.)

10. Match the following terms (on the left) to their definitions (on the right). Draw a line from the term to its definition.

- | | |
|-------------|-------------------------------------|
| A. Filly | 1. An unweaned horse |
| B. Mare | 2. A male horse that is castrated |
| C. Colt | 3. Female horse under age 3 |
| D. Foal | 4. A mature female, age 3 or older |
| E. Gelding | 5. A male horse able to sire a foal |
| F. Stallion | 6. Male horse under age 3 |

11. Name five items that you should take with you when you go on a trail ride.

- 1.
- 2.
- 3.
- 4.
- 5.

12. Identify the following parts of the western saddle. Write their names in the boxes.

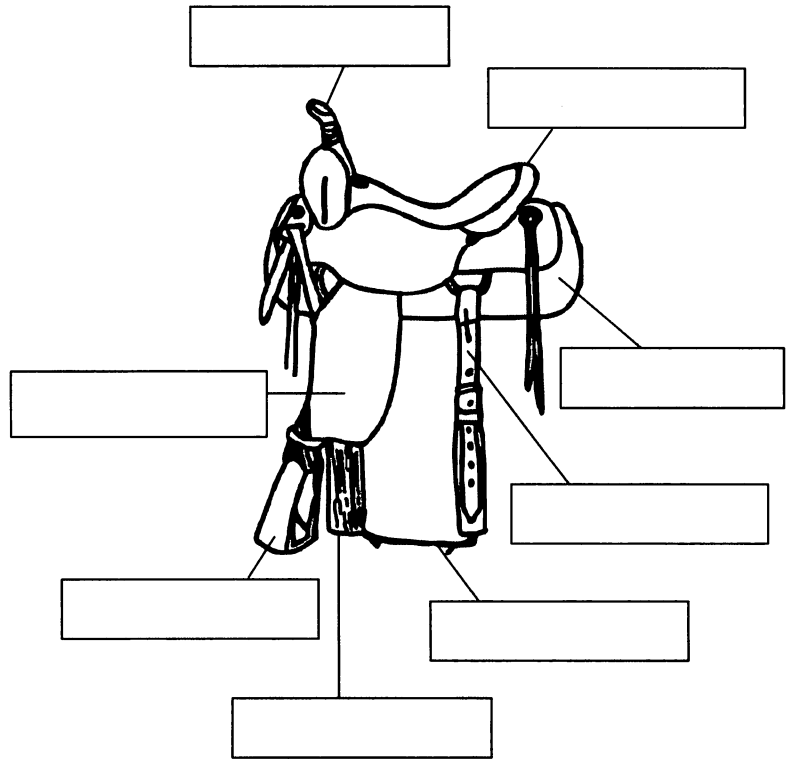

13. Identify the following parts of the western bridle. Write their names in the boxes.

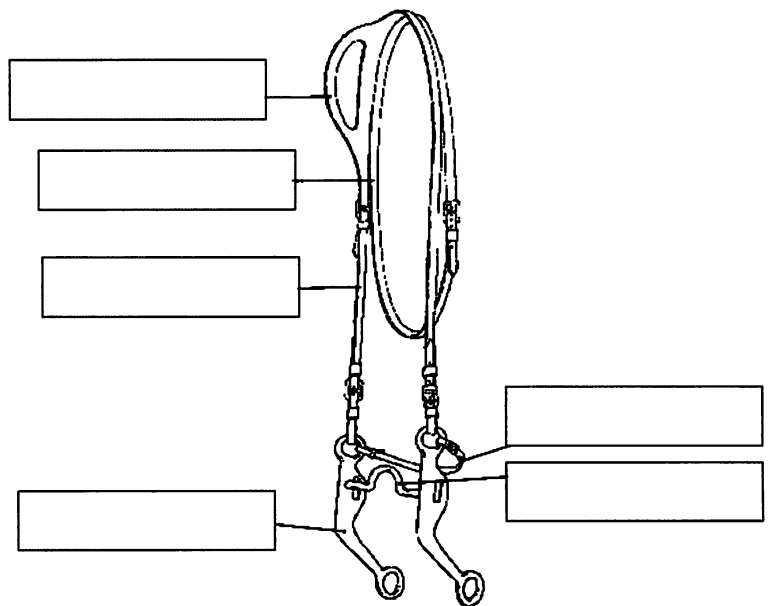

1 KNOWLEDGE ADVANCEMENTS (contd.)

14. On the pictures below, draw the following leg markings: coronet, pastern, ankle, sock (half-stocking), stocking, and full stocking.

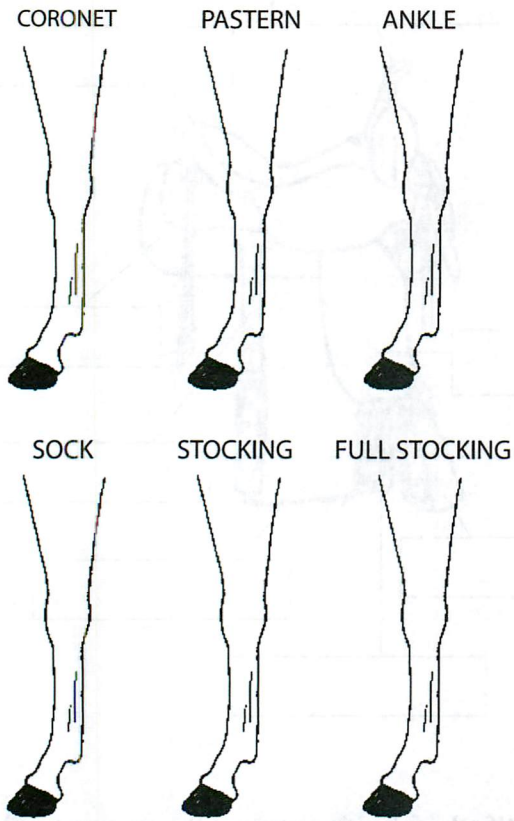

15. On the picture below, draw a line indicating where you would measure the horse's height.

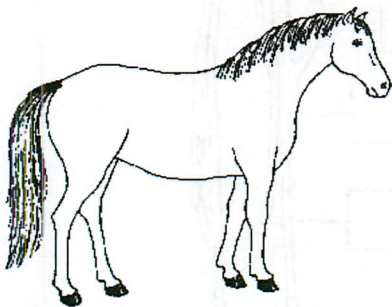

16. Match the following gaits (on the left) to their descriptions (on the right). Draw a line from the gait to its description.

- | | |
|-----------------|--|
| A. Walk | 1. Western term for slow trot |
| B. Sitting trot | 2. Western term for the three-beat gait |
| C. Posting trot | 3. English term for free-moving, two-beat gait |
| D. Canter | 4. Four-beat gait |
| E. Jog | 5. English term for smooth, three-beat gait |
| F. Lope | 6. English term for a two-beat gait slower than a posting trot |

17. Identify the following parts of the horse. Write their names in the boxes.

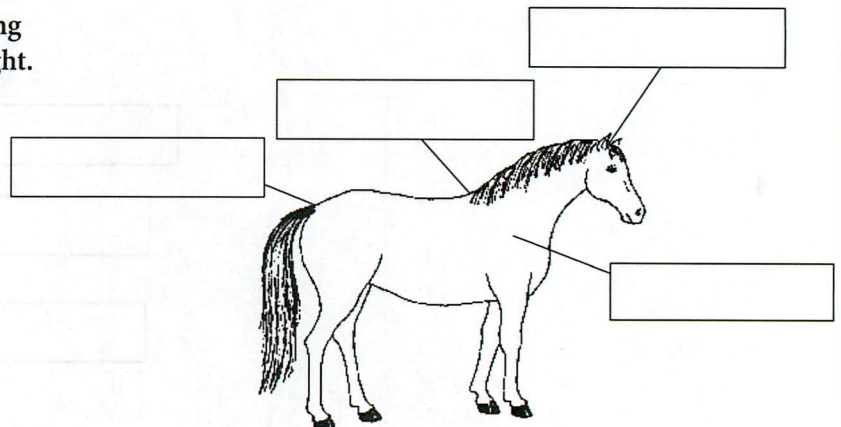

Congratulations! You have successfully completed Level 1 of the Knowledge Advancements!

_____ has satisfactorily completed all of the above knowledge elements and has, therefore, completed Level 1 of the Oregon 4-H Knowledge Advancements.

Name of Club Member _____

Leader's Signature: _____ Date Approved: _____

1 GROUND WORK ADVANCEMENTS

1. Ask your club leader to watch you perform the following ground work elements and sign off that you perform them accurately and safely.

Element	Date Completed	Leader's Initials
Demonstrate proper quartering		
Pose your horse (as in showmanship)		
Back from the ground the requested number of steps		
Halter your horse (showing proper halter adjustment)		
Tie your horse with a quick-release knot		
Properly brush your horse		
Lead your horse at a walk and trot from the near side		
Perform a 90-degree haunch turn (both directions)		
Demonstrate how to properly approach and catch your horse		
Show how to properly attach a chain over the nose and under the chin		

2. What is the purpose of showmanship in 4-H?

3. If a chain is used in showmanship, approximately how long should it be?

_____ inches

4. What are the five areas of the horse you should clip for a show?

- 1.
- 2.
- 3.
- 4.
- 5.

Congratulations! You have successfully completed Level 1 of the Ground Work Advancements!

Name of Club Member

has satisfactorily completed all of the above ground work elements and has, therefore, completed Level 1 of the Oregon 4-H Ground Work Advancements.

Leader's Signature: _____ Date Approved: _____

1 RIDING ADVANCEMENTS

1. Ask your club leader to watch you perform the following riding elements and sign off that you perform them accurately and safely.

Element	Date Completed	Leader's Initials
Mount your horse from the near side		
Dismount your horse from the near side		
Perform a serpentine at a walk and trot		
Canter/lope on the rail (both directions)		
Halt from a walk, trot, and canter/lope		
Perform a series of figure 8s at the trot, changing diagonals		
Perform a series of figure 8s at the canter/lope, executing a simple change of lead		
Perform a 180-degree haunch turn (both directions)		
Perform a 180-degree forehand turn (both directions)		
Perform a posting trot on a straightaway and change diagonals three times as requested by your leader (Dad Potter Step #7)		
Walk forward and backward the exact number of steps requested (Dad Potter Step #1)		

2. Describe one way to cue a horse to stop.

3. Describe one way to make a horse trot.

4. What are three aids (natural or artificial) that you might use when riding your horse?

- 1.
- 2.
- 3.

5. What are three things you should consider when choosing a riding instructor?

- 1.
- 2.
- 3.

Congratulations! You have successfully completed Level 1 of the Riding Advancements!

_____ has satisfactorily completed all of the above riding elements and has, therefore, completed Level 1 of the Oregon 4-H Riding Advancements.

Name of Club Member

Leader's Signature: _____ Date Approved: _____

1 PERSONAL DEVELOPMENT ADVANCEMENTS

Members should complete at least two personal development options each year. Indicate the personal development options that you complete and ask your leader to sign off that you have completed them.

Option	Date Completed	Leader's Signature
Lead the Pledge of Allegiance and the 4-H pledge at a club meeting	_____	_____
Observe a horse being shod	_____	_____
Visit a tack store	_____	_____
Read a horse book	_____	_____
Attend a 4-H camp	_____	_____
Serve as host for a 4-H meeting	_____	_____
Give a presentation	_____	_____
Create an educational display	_____	_____
Participate in a judging contest	_____	_____
Participate in a hippology contest	_____	_____
Participate in a horse bowl contest	_____	_____
Participate in your county fair	_____	_____
Participate in a community service project	_____	_____
Conduct a horse-related science inquiry	_____	_____
Other: _____	_____	_____
Other: _____	_____	_____
Other: _____	_____	_____

Congratulations! You have successfully completed Level 1 of the Personal Development Advancements!

<p>_____</p> <p><i>Name of Club Member</i></p>	<p>has satisfactorily performed the required amount of personal development options listed above and has, therefore, completed Level 1 of the Oregon 4-H Personal Development Advancements.</p>
<p>Leader's Signature: _____</p>	<p>Date Approved: _____</p>

2 KNOWLEDGE ADVANCEMENTS

1. What are five signs of a normal, healthy horse?

- 1.
- 2.
- 3.
- 4.
- 5.

2. Name five diseases that you can (and should) vaccinate your horse for.

- 1.
- 2.
- 3.
- 4.
- 5.

3. Match the following internal parasites (on the left) to their descriptions (on the right). Draw a line from the parasite to its description.

- | | |
|---------------------|---------------------------|
| A. Large strongyles | 1. Least harmful |
| B. Ascarids | 2. Largest |
| C. Pinworms | 3. Most harmful |
| D. Tapeworms | 4. Larvae of bot fly |
| E. Bots | 5. Require immediate host |

4. What are three ways to control internal parasites?

- 1.
- 2.
- 3.

5. Name three external parasites and list one control method for each of them.

Parasite	Control Method

6. What are the six essential nutrients?

- 1.
- 2.
- 3.
- 4.
- 5.
- 6.

2 KNOWLEDGE ADVANCEMENTS (contd.)

7. List the three types of hunt seat saddles and a feature of each one.

- 1.
- 2.
- 3.

8. Below are various examples of aids that you might use when riding your horse. In the space provided, write an "N" if the aid is a natural aid or an "A" if it is an artificial aid.

- _____ Hands
- _____ Crop
- _____ Legs
- _____ Weight
- _____ Spurs
- _____ Voice

9. How long is a horse's gestation period?

10. What is the name of the concentrated milk that a dam secretes for the first few days after giving birth?

11. Below are various qualities of hay. Circle the qualities that are good for hay to have. Cross out the qualities that are bad for hay to have.

- Cut when mature
- Green
- Low leaf-to-stem ratio
- Sweet smelling
- Free of weeds, dust, and dirt
- Moldy

12. What are the two categories of hay?

- 1.
- 2.

13. Name two types of legumes.

- 1.
- 2.

14. Name three types of grass hay.

- 1.
- 2.
- 3.

15. Identify the following parts of the curb bit. Write their names below.

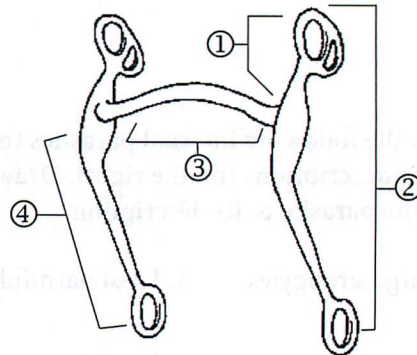

- ① _____
- ② _____
- ③ _____
- ④ _____

2 KNOWLEDGE ADVANCEMENTS (contd.)

16. Name and briefly describe the three types of lead changes.

1. _____
2. _____
3. _____

17. What are five items you should have in your equine first aid kit?

1. _____
2. _____
3. _____
4. _____
5. _____

18. What are five factors you should consider when looking to buy a horse?

1. _____
2. _____
3. _____
4. _____
5. _____

19. What is a horse's normal temperature?

_____ degrees Fahrenheit

20. What is a horse's normal standing pulse?

_____ beats/minute

21. What is a horse's normal standing respiration rate?

_____ breaths/minute

22. What are two benefits of controlling your horse's grazing?

1. _____
2. _____

23. Briefly describe how you should store the following items of tack.

1. Bridle: _____
2. Saddle: _____
3. Blanket: _____

24. What is the definition of a stable vice?

Congratulations! You have successfully completed Level 2 of the Knowledge Advancements!

_____ has satisfactorily completed all of the above knowledge elements and has, therefore, completed Level 2 of the Oregon 4-H Knowledge Advancements.

Name of Club Member

Leader's Signature: _____ Date Approved: _____

2 GROUND WORK ADVANCEMENTS

1. Ask your club leader to watch you perform the following ground work elements and sign off that you perform them accurately and safely.

Element	Date Completed	Leader's Initials
Tie a bowline knot		
Pick up and clean front and back hooves		
Saddle your horse		
Bridle your horse		
Unsaddle your horse		
Unbridle your horse		
Perform a 180-degree haunch turn (both directions)		
Perform a 180-degree forehand turn (both directions)		
Lead your horse from the off side at a walk		

2. What are two benefits of longeing your horse?

- 1.
- 2.

3. Why is it important that your horse learns to stand still while you pick up its feet?

4. Describe how to safely load a horse in a trailer.

5. How long should a lead rope be for showing?

_____ feet

6. Describe how to safely cross-tie a horse.

Congratulations! You have successfully completed Level 2 of the Ground Work Advancements!

_____ has satisfactorily completed all of the above ground work elements and has, therefore, completed Level 2 of the Oregon 4-H Ground Work Advancements.

Name of Club Member

Leader's Signature: _____ Date Approved: _____

2 RIDING ADVANCEMENTS

1. Ask your club leader to watch you perform the following riding elements and sign off that you perform them accurately and safely.

Element	Date Completed	Leader's Initials
Mount your horse from the off side		
Dismount your horse from the off side		
Pick up a canter/lope from walk (both leads)		
Pick up a canter/lope from trot (both leads)		
Perform an extended jog/trot		
Sidepass at least 12 steps (both directions) with the forefeet completely crossing over (Dad Potter Step #2)		
Stand still for 10 seconds		
Perform a 360-degree haunch turn (both directions), keeping the pivot foot in a 3-foot circle and maintaining forward motion (Dad Potter Step #4)		
Perform a 360-degree forehand turn (both directions), keeping the pivot foot in a 2-foot circle and maintaining forward motion (Dad Potter Step #3)		
Demonstrate proper body and leg position at all gaits		
Demonstrate how to properly hold split reins and romal reins		

2. Name three general safety rules that 4-H members should observe when riding their horses.

- 1.
- 2.
- 3.

3. Name three safety rules that 4-H members should observe when riding on the trail.

- 1.
- 2.
- 3.

Congratulations! You have successfully completed Level 2 of the Riding Advancements!

_____ has satisfactorily completed all of the above riding elements and has, therefore, completed Level 2 of the Oregon 4-H Riding Advancements.

Name of Club Member

Leader's Signature: _____ Date Approved: _____

2 PERSONAL DEVELOPMENT ADVANCEMENTS

Members should complete at least two personal development options each year. Indicate the personal development options that you complete and ask your leader to sign off that you have completed them.

Option	Date Completed	Leader's Signature
Lead the pledges at a 4-H event	_____	_____
Visit a horse training or breeding facility	_____	_____
Visit a large, open horse show	_____	_____
Serve as a Junior Leader	_____	_____
Make arrangements for a tour for your club	_____	_____
Secure a speaker to talk at a club meeting	_____	_____
Lead an activity at a club meeting	_____	_____
Attend a state 4-H event	_____	_____
Give a presentation	_____	_____
Create an educational display	_____	_____
Participate in a judging contest	_____	_____
Participate in a hippology contest	_____	_____
Participate in a horse bowl contest	_____	_____
Participate in your county fair	_____	_____
Participate in a community service project	_____	_____
Conduct a horse-related science inquiry	_____	_____
Other: _____	_____	_____
Other: _____	_____	_____
Other: _____	_____	_____

Congratulations! You have successfully completed Level 2 of the Personal Development Advancements!

_____ <i>Name of Club Member</i>	has satisfactorily performed the required amount of personal development options listed above and has, therefore, completed Level 2 of the Oregon 4-H Personal Development Advancements.
Leader's Signature: _____	Date Approved: _____

3 KNOWLEDGE ADVANCEMENTS

1. Match the following grains (on the left) with their descriptions (on the right). Draw a line from the grain to its description.

- | | |
|-----------|--|
| A. Oats | 1. Susceptible to ergot fungus |
| B. Barley | 2. Easy to digest; soft and easy to roll |
| C. Corn | 3. Must be fed crimped or rolled |
| D. Wheat | 4. Can be lethal when moldy |
| E. Rye | 5. High in energy; expensive |

2. Name three common protein supplements.

- 1.
- 2.
- 3.

3. Name three common fat supplements.

- 1.
- 2.
- 3.

4. When should you add a supplement to your horse's diet?

5. What are three things that you should do to ensure your horse stays healthy when the weather is cold?

- 1.
- 2.
- 3.

6. What are four health problems that are common during the hotter months of the year?

- 1.
- 2.
- 3.
- 4.

7. What are three ways that you can prevent heat-related health problems?

- 1.
- 2.
- 3.

8. Below are scenarios that depict health issues your horse may experience. Write a "Y" if you should call a veterinarian in the situation; write an "N" if you should not call a veterinarian.

- _____ Your horse has a temperature of 101 degrees Fahrenheit.
- _____ Your horse has a deep puncture wound.
- _____ Your horse appears to have a broken bone.
- _____ Your horse appears to be limping a bit.
- _____ Your horse has persistent diarrhea.
- _____ Your horse has a wound that appears to be infected.

9. Identify the following parts of the hoof. Write their names in the boxes.

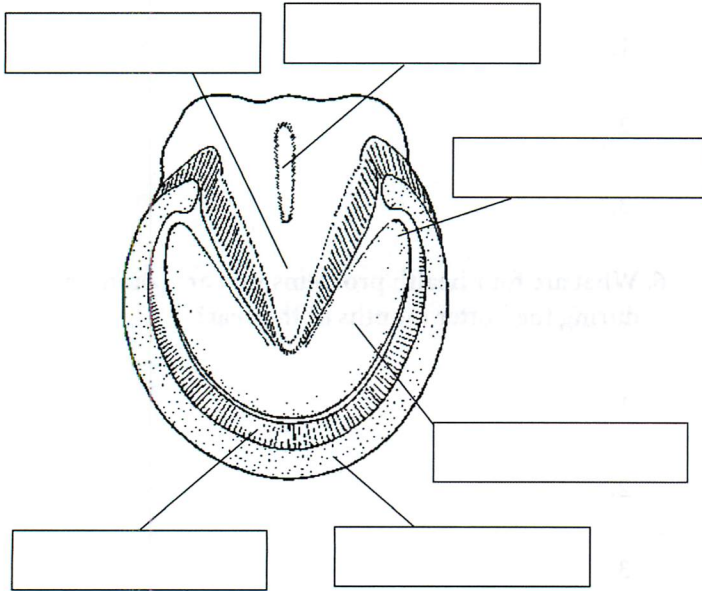

10. Match the following unsoundnesses and/or conformation faults (on the left) to their definitions (on the right). Draw a line from the conformation fault/unsoundness to its definition.

- | | |
|----------------|---|
| A. Bone spavin | 1. Depression of the muscle mass in the shoulder caused by an injury to a nerve |
| B. Bog spavin | 2. Puffy condition in the hollow of the hock |
| C. Thoroughpin | 3. Soft filling of the natural depression on the inside and front of the hock |
| D. Calf-knees | 4. Knees that protrude too far forward when viewed from the side |
| E. Buck-knees | 5. Knees that break backward when viewed from the side |
| F. Sweeney | 6. Bony enlargement on the inside and front of the hock |

11. How many permanent teeth do adult male horses have?

12. How many permanent teeth do adult female horses have?

13. Put the following teeth in order from youngest to oldest. Write the order in the space provided below.

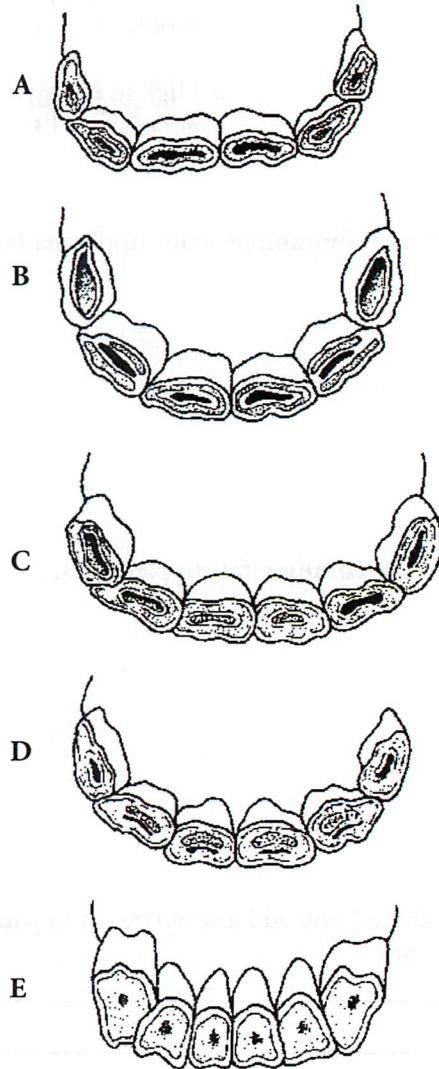

Youngest

Oldest

3 KNOWLEDGE ADVANCEMENTS (contd.)

14. What are two ways that you can test to see if your horse is dehydrated?

- 1.
- 2.

15. Briefly describe the following stable vices.

Cribbing:

Wood chewing:

Weaving:

Stall walking:

16. What are five things that you can do to prevent a fire in your barn?

- 1.
- 2.
- 3.
- 4.
- 5.

17. Below are four things you should do if a fire ever breaks out in your barn. Number them in order, with "1" as the first thing you should do and "4" as the last.

- _____ Open one door of the stable.
- _____ Save equipment from the stable (if it is safe to go in the barn).
- _____ Lead the horses out of the stable (if it is safe to go in the barn).
- _____ Call the fire department.

18. Rate the following plants on their level of toxicity to horses. Use the following ranking system: 5 = very high toxicity, 4 = high toxicity, 3 = moderate toxicity, 2 = low toxicity, and 1 = no toxicity.

- _____ Chokecherry
- _____ Nightshade
- _____ Yew
- _____ Foxglove
- _____ Bracken fern
- _____ Water hemlock
- _____ Elderberry

3 KNOWLEDGE ADVANCEMENTS (contd.)

19. Below are various diseases. Circle the diseases that currently have a cure.

- West Nile virus
- Equine encephalomyelitis
- Rabies
- Tetanus
- Equine infectious anemia
- Equine influenza
- Potomac horse fever
- Strangles

20. Match the following diseases (on the left) to their descriptions (on the right). Draw a line from the disease to its description.

- | | |
|--------------|--|
| A. Tetanus | 1. Contagious upper respiratory disease |
| B. Strangles | 2. Caused by protozoa found in opossums |
| C. Influenza | 3. Serious disease; also called "lockjaw" |
| D. Rabies | 4. Mosquito-borne virus; causes encephalitis |
| E. EPM | 5. Common viral respiratory disease |
| F. EIA | 6. Seasonal disease; occurs mostly in summer |
| G. PHF | 7. Rare disease; 100% fatal |
| H. West Nile | 8. Also called "swamp fever;" no vaccine to prevent it |

21. Identify the following parts of the horse's skeleton. Write their names below.

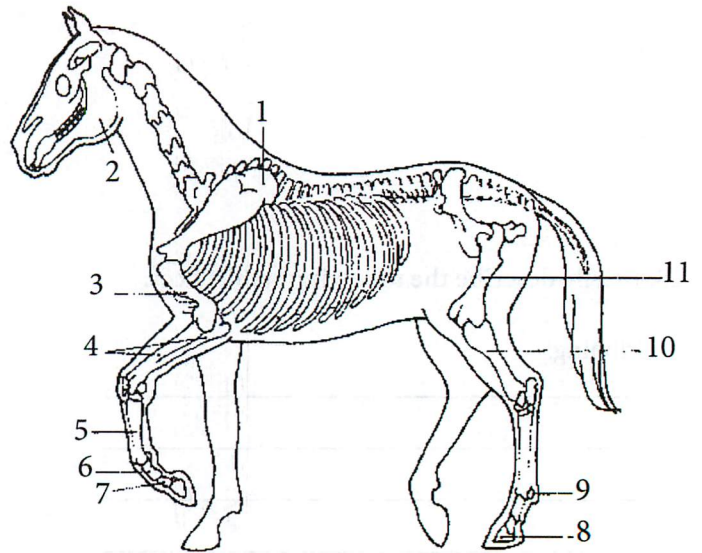

1. _____
2. _____
3. _____
4. _____
5. _____
6. _____
7. _____
8. _____
9. _____
10. _____
11. _____

3 KNOWLEDGE ADVANCEMENTS (contd.)

22. Briefly describe the following common hoof problems.

Thrush:

White line disease:

Sand cracks:

Laminitis:

Navicular disease:

23. Name the following boots and give an example of when you would use each type.

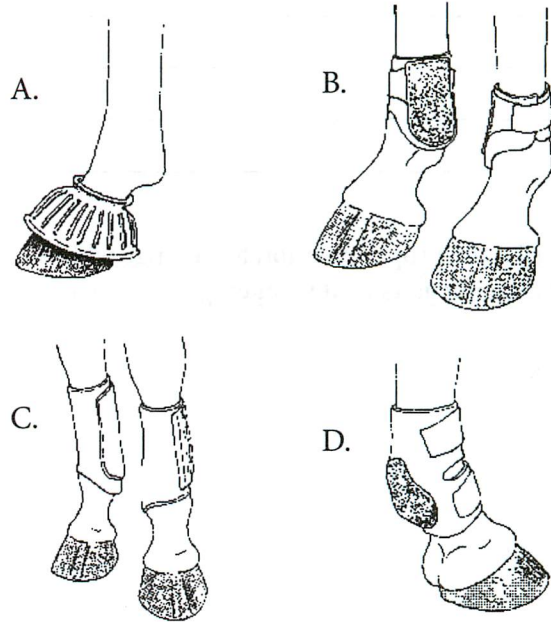

A. Name: _____

Use: _____

B. Name: _____

Use: _____

C. Name: _____

Use: _____

D. Name: _____

Use: _____

Congratulations! You have successfully completed Level 3 of the Knowledge Advancements!

Name of Club Member

has satisfactorily completed all of the above knowledge elements and has, therefore, completed Level 3 of the Oregon 4-H Knowledge Advancements.

Leader's Signature: _____ Date Approved: _____

3 GROUND WORK ADVANCEMENTS

1. Explain how you can tell whether a horse's halter is correctly adjusted and why an incorrectly adjusted halter is unsafe.

2. Describe the proper position for a longe whip at the following gaits while longeing your horse:

1. Walk:

2. Trot:

3. Canter:

3. Why should you not use a lead rope to longe a colt?

4. Ask your club leader to watch you perform the following ground work elements and sign off that you perform them accurately and safely.

Element	Date Completed	Leader's Initials
Sidepass the correct number of steps (both directions)		
Perform a 360-degree forehand turn (both directions)		
Perform a 360-degree haunch turn (both directions)		
Lead your horse from the off side at a trot		
Back your horse around a cone		
Work horse at all gaits on the longe line		
Clip your horse		

Congratulations! You have successfully completed Level 3 of the Ground Work Advancements!

_____ has satisfactorily completed all of the above ground work elements and has, therefore, completed Level 3 of the Oregon 4-H Ground Work Advancements.

Name of Club Member

Leader's Signature: _____ Date Approved: _____

3 RIDING ADVANCEMENTS

1. Describe what is meant by the term “light hand” and why a light hand is beneficial to the horse.

2. Ask your club leader to watch you perform the following riding elements and sign off that you perform them accurately and safely.

Element	Date Completed	Leader's Initials
Pick up a jog/trot from a standing position (Dad Potter Step #6)		
Pick up a canter/lope from halt (both leads)		
Perform a figure 8 at a canter/lope, executing an interrupted change of lead (Dad Potter Step #8)		
Perform an interrupted change of lead on a straight line		
Perform a figure 8 at a canter/lope, executing a flying change of lead		
Perform two flying lead changes on a straight line (Dad Potter Step #10)		
Hand gallop (both directions)		
Perform a figure 8, executing a flying lead change, then continue on to 2 circles to the left/right, another lead change, then 2 circles in the other direction (Dad Potter Step #6)		
Two track (both directions) (Dad Potter Step #5)		
Demonstrate collection at all gaits		

Congratulations! You have successfully completed Level 3 of the Riding Advancements!

_____ has satisfactorily completed all of the above riding elements and
Name of Club Member has, therefore, completed Level 3 of the Oregon 4-H Riding Advancements.

Leader's Signature: _____ Date Approved: _____

3 PERSONAL DEVELOPMENT ADVANCEMENTS

Members should complete at least two personal development options each year. Indicate the personal development options that you complete and ask your leader to sign off that you have completed them.

Option	Date Completed	Leader's Signature
Serve as a club officer	_____	_____
Serve as a teen leader	_____	_____
Be a teen counselor at a 4-H camp	_____	_____
Serve on a state planning committee	_____	_____
Serve as teen staff at State Fair	_____	_____
Write a news story for a local newspaper	_____	_____
Discuss preventative medicine with a veterinarian	_____	_____
Have a feed, soil, or fecal sample analyzed	_____	_____
Make an emergency plan for your barn	_____	_____
Conduct a safety inspection of your stall/barn	_____	_____
Interview a professional in a horse career	_____	_____
Give a presentation	_____	_____
Create an educational display	_____	_____
Participate in a judging contest	_____	_____
Participate in a hippology contest	_____	_____
Participate in a horse bowl contest	_____	_____
Participate in your county fair	_____	_____
Participate in a community service project	_____	_____
Conduct a horse-related science inquiry	_____	_____
Other: _____	_____	_____
Other: _____	_____	_____
Other: _____	_____	_____

Congratulations! You have successfully completed Level 3 of the Personal Development Advancements!

_____ <i>Name of Club Member</i>	has satisfactorily performed the required amount of personal development options listed above and has, therefore, completed Level 3 of the Oregon 4-H Personal Development Advancements.
Leader's Signature: _____	Date Approved: _____